



## Analysis and Evaluation of Dual Axis Solar Tracker based on Light Sensor

Sourav Singh<sup>1</sup>, Ravindra Kumar Jain<sup>2</sup>, Mukesh Kumar Gupta<sup>3</sup>

<sup>1</sup>M.Tech Dual Degree Scholar (Energy Engg.), Suresh Gyan Vihar University, Jaipur,

<sup>2,3</sup>Centre of Excellence-Renewable & Sustainable Energy Studies, Suresh Gyan Vihar University, Jaipur – India

### ABSTRACT

This paper is concerning to find the optimum utilization of solar radiation through standard Double Axis Tracking system and to compare the efficiency of single axis stationary solar panel and standard double axis tracking panel. In this modern world, need of electricity is more demand. There are so many renewable source of energy available, solar energy is most important one of them. The author has fabricated the dual axis solar tracking system to utilize the optimum power from the solar radiation. Proposed system was kept under observation for about 30-35 days during the month of Sept-Oct 2015. Data was taken on each day during the observation period. Data of only one day was in research paper due to availability of space in the paper. In the research, author used Computer base programming to locate the maximum solar radiation. Power gain percentage is compared with static and continuous double axis tracking system. It was observed that nearly gain of 5% in power generation with continuous dual axis tracking system can be achieved.

**KEYWORDS:** PV panel, Efficiency, conventional, renewable, tracking system.

Received 05 December, 2020; Accepted 20 December, 2020 © The author(s) 2020.

Published with open access at [www.questjournals.org](http://www.questjournals.org)

### I. INTRODUCTION

Nowadays electrical energy is the most important part of our routine life and has been playing an important role in human and nation economic development and for world peace. During previous years, non-conventional sources as solar energy have attracted importance over the world. Among all the energy sources, solar energy is an important and prerequisite source in a sustainable form [1,2].

Solar energy conversion is the process through which Sun rays are converted into electrical or heat form of energy with the help of Photovoltaic cells or solar heater. The system of conversion of energy is very similar to the p-n junction diode. Photon is present in the sunlight as particles. Photovoltaic (PV) cells are made of semiconductor materials that absorb the photon present in the sunlight. Due to this electron excited and flow of electrons through the materials to generate the Electrical current [3,4]. The solar panel is of crystalline silicon cells. Manufacturer's Technical Specification of solar PV panel is as follows, Material of solar cell: Silicon, Open Circuit Voltage: 23 V, Maximum Voltage: 18.9 V, Collector Area: 0.25 m<sup>2</sup>, Maximum Power: 100W, Power Tolerance: +/- 3%. Module Efficiency: 14-15%, Operating Conditions: -40 to +55 °C.

Solar Energy is the best form of energy that can be utilized to full fill the production of electricity worldwide. The higher degree of accuracy and precision can be obtained by various changes in the system of tracking.

Several changes have been investigated worldwide. Generally, they are classified as both open-loop tracking and close loop tracking. Based on solar movement, in open-loop tracking, tracking formula, control algorithm, and loop tracking types which are based on sensor-based feedback controller [5]. Azimuth and angles elevation of the Sun was determined by the solar mathematical model. Mathematical algorithm for a given date and time at the particular geographical locations. These algorithms were run in the microcontroller.

In the closed-loop Tracking system, various sensors like light-dependent resistors or charge couples devices are used. These devices sense the sun's location and feedback signal sent to the control system to align the panel accordingly to the sun's locations.[6,7,8]

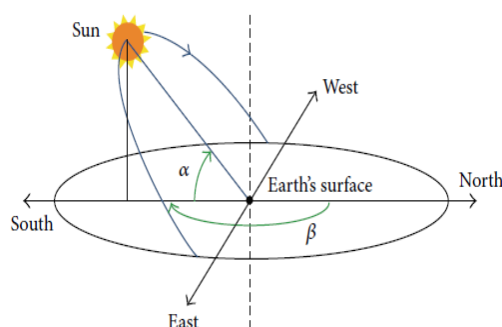

**Figure 1:** Diagram for solar angles:  $\alpha$ - altitude angle,  $\beta$ - azimuth angle

The path of the solar system changes day by day. In the hemisphere of the north, sunrise in the winter season and sunset time is changing accordingly. At Solar noontime, when  $\beta = 180^\circ$  degree, the sun is in the south direction and sunrise and sunset halfway.

## II. DESIGN IMPLEMENTATION AND METHODOLOGY

The complete work engages the reading which was taken with the help of the Light Dependent Resistors (LDRs) sensor and these digital readings were comparing to find the optimum direction of the panel to get the maximum amount of sun rays and align the panel in the east-west direction as well as altitude angle also[9,10]. In this research work, the panel direction runs east to west and altitude angle also. As we know the sun rises in the east and sets in the west. The orientation of the solar panel is defined based on the azimuth and tilt angle. The sun travels from east to south (in the sky) to the west. The orientation of the static Solar Panel is in the South Face to generate the maximum amount of power from maximum Sun rays during the day. Artificial intelligence used to analyze the Sun movement in a direction, that is, vertically and horizontally.

In simple word, the whole system can be divided into two parts:

- (1) Mechanical Part
- (2) Electrical Circuit Design
- (3) Software Coding

### **Mechanical Part:**

The most challenging work in this research work is to design and assembling the solar panel to achieve the objective of the research for the maximum efficiency of the solar panel. Energy-efficient solar tracking demands the highly efficient movement panel for solar tracking. The motor used for daily and seasonal tracking is wiper motor. Tracking motor operates on day to day basis continuously based on LDRs sensor and seasonal tracking operates on a few days over a year track the sun. The whole mechanical system was divided into the following parts.

- (a) The base of the Panel
- (b) Solar Panel frame which was mounted over the base
- (c) Wiper Motor used for tracking



**Figure 2:** PWM Controlled Motor for the tracking of the Solar panel

**Electrical circuit part:**

The electrical circuit design is the nervous system of the dual-axis solar tracking system. The whole electrical circuit part is divided into parts.

- (a) LDRs based sensor unit
- (b) Control unit
- (c) Movement alignment unit

LDRs sensor unit used for the intensity of sunlight, it converts the sunlight into voltage signals [11]. These voltage signals were compared and investigate with the help of a microcontroller. The control unit receives signals that were sent to the microcontroller system. Now, the control unit will analyze the signals and determine the direction of the movement of the solar panel move east to west and north to south. The control unit sent the signal to the rotary actuator to align the position of the solar panel according to the signals received to the control unit.

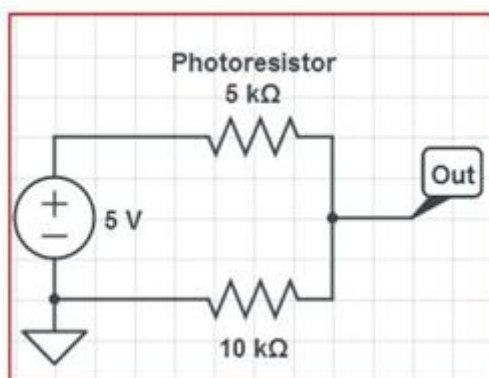

*Figure 3: Circuit diagram of Light detection (DDR) sensor*

The speed and direction of the motor were controlled with the help of the Modulation circuit of the Pulse width for the smooth movement of the solar panel in any direction.

*Figure 3: Circuit diagram of Light detection (DDR) sensor*

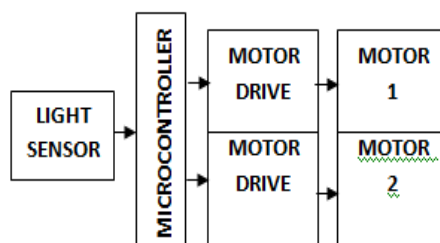

*Figure 4: Block Diagram of Electrical circuit*

**Software Coding:**

Programmable Interface Controller in Microcontrollers can be programmed in either machine language (Assembly) or high-level languages. Micro C software is used to programmed the algorithm in C language. The benefits of using this language are efficient to control and better flexibility. The major benefit is, it is easy to understand and simple with the interface. Algorithm of programming is as follow:

**Case 1:** LDR1 light intensity < LDR2 light intensity & LDR3 light intensity < LDR4 light intensity.

If LDR sensor 2 and LDR sensor 4 have the highest value of voltage develops due to solar intensity hitting directly to it. For example, Direct Current (DC) Motor (A) rotates in the clockwise direction. Movement of elevation of the solar axis tracker in a clockwise direction is controlled by DC motor A.

**Case 2:** LDR1, light intensity > LDR2, light intensity & LDR-3, light intensity > LDR4, light intensity.

If LDR sensor 1 and LDR sensor 3 has the highest value of voltage develops due to solar intensity hitting directly to it. For case 2, DC Motor A rotates in the anticlockwise direction. Movement of elevation of the solar axis tracker in the anti-clockwise direction is controlled by DC motor A.

**Case 3:** LDR1 light intensity >LDR3 light intensity & LDR2 light intensity>LDR4 light intensity.

If LDR sensor 1 and LDR sensor 2 has the highest value of voltage develops due to solar intensity hitting directly to sensor LDR1 & 2. For case 3, DC Motor B rotates in the clockwise direction. Thus the DC motor B will control the movement of solar panel in the vertical axis to main the minimum possible angle of the line of sun intensity and the perpendicular line to the solar panel.

**Case 4:** LDR1 light intensity < LDR3 light intensity & LDR2 light intensity < LDR4 light intensity.

In this case, the sun intensity hitting directly to the LDR sensor 3 and LDR sensor 4, has the highest value of voltage develops due to solar intensity hitting directly to sensor LDR3 & LDR4. For case 4, DC Motor B rotates in the anti-clockwise direction. thus the DC motor B will control the movement of solar panel in the vertical axis to main the minimum possible angle of the line of sun intensity and the perpendicular line to the solar panel.

**Case5:** LDR1 light intensity = LDR2 light intensity = LDR3 light intensity = LDR4 light intensity in the last case number 5, if the value of voltage develops in the Sensor LDRs have the same value in the range. There will be no movement of the panel either in the vertical or horizontal directions. In this case, the entire sensors compare the microcontroller value.

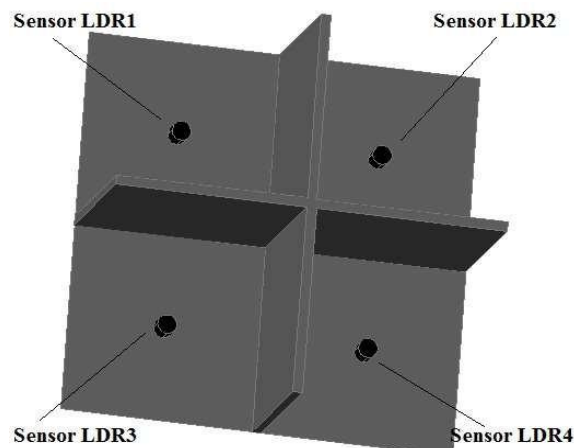

*Figure 5: Sensor LDRs Position*

### III. FLOWCHART OF THE PROGRAMME

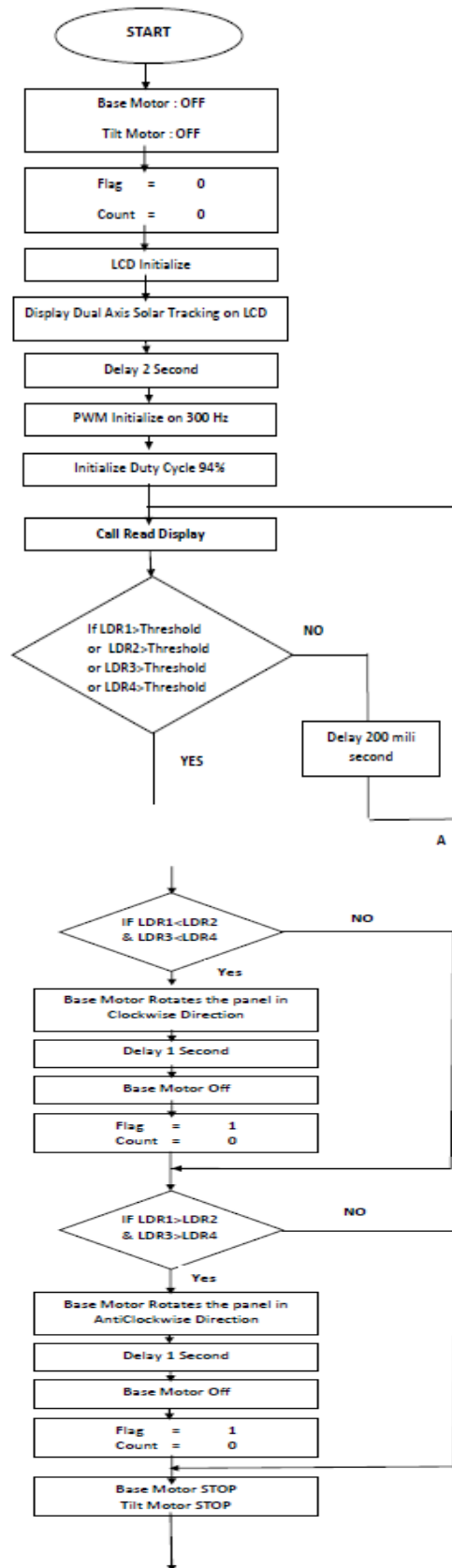

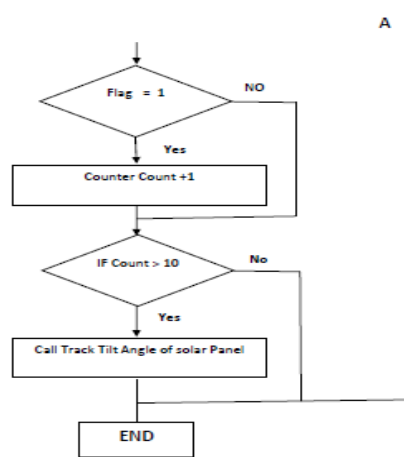

Figure 6: Main Flow Diagram for Microcontroller Programming

#### IV. CALCULATION OF EFFICIENCY FOR DUAL AXIS SOLAR TRACKING SYSTEM

Reading and Calculation for both the system types were investigated and analyzed with the help of various equipment and software. Data were analyzed for comparison purposes.

Effective Area of solar panel = 0.25 m<sup>2</sup>

Power = Voltage<sub>solar</sub> × Current<sub>solar</sub>

$$Efficiency(\eta) = \frac{Power\ Output}{Solar\ Radiation * Collector\ Area} \quad \eta = \frac{P(W)}{E\left(\frac{W}{m^2}\right) * A(m^2)}$$

The whole calculation was done with the help of the above mathematical formula. The power output for the dual-axis and fixed mount panel are tabulated for a single day. The average power values prove that the dual-axis panel produces more power than that of the fixed mount. The power efficiency calculated for the single-axis solar tracker is said to be approx 5% more than that of the fixed mount. The tabulated values are simulated and the graph is generated using MS Excel

Table I: Data Observation for Dual Axis Solar Tracking System on 24/10/2015

Time	Radiation (W/m <sup>2</sup> )	Current Supplied to Battery (I)	Power (W)	Efficiency (η)
10:00 AM	760	1.54	20.41	10.74
10:15 AM	780	1.54	20.42	10.47
10:30 AM	770	1.53	20.32	10.56
10:45 AM	800	1.55	20.58	10.29
11:00 AM	810	1.55	20.63	10.19
11:15 AM	800	1.59	21.16	10.58
11:30 AM	805	1.59	21.18	10.52
11:45 AM	840	1.59	21.18	10.09
12:00 PM	850	1.6	21.36	10.05
12:15 PM	860	1.6	21.38	9.94
12:30 PM	876	1.64	21.89	10
12:45 PM	890	1.64	21.94	9.86
1:00 PM	880	1.65	22.09	10.04
1:15 PM	910	1.65	22.09	9.71
1:30 PM	930	1.65	22.11	9.51
1:45 PM	914	1.67	22.38	9.79
2:00 PM	870	1.68	22.53	10.36
2:15 PM	880	1.68	22.53	10.24
2:30 PM	850	1.68	22.55	10.61

2:45 PM	890	1.67	22.41	10.07
3:00 PM	860	1.68	22.6	10.51
3:15 PM	845	1.65	22.19	10.51
3:30 PM	790	1.65	22.24	11.26
3:45 PM	705	1.54	20.76	11.78
4:00 PM	710	1.57	21.21	11.95

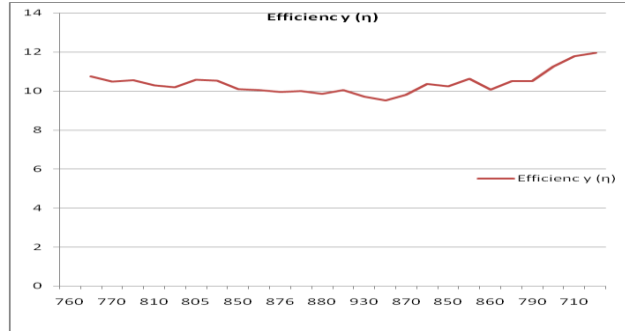

Figure 7: Efficiency V/s Solar Radiation Graph for Dual Axis solar System

Table II: Data Observation for Static Solar System on 24/10/2015

Time	Radiation (W/m <sup>2</sup> )	Battery Voltage (V)	Battery Current (I)	Power (W)	Efficiency (η)
10:00 AM	760	13.25	0.71	9.41	4.95
10:15 AM	780	13.26	0.71	9.41	4.83
10:30 AM	770	13.28	0.71	9.43	4.9
10:45 AM	800	13.28	0.71	9.43	4.71
11:00 AM	810	13.31	0.73	9.72	4.8
11:15 AM	800	13.31	0.74	9.85	4.92
11:30 AM	805	13.32	0.75	9.99	4.96
11:45 AM	840	13.32	0.76	10.12	4.82
12:00 PM	850	13.35	0.76	10.15	4.77
12:15 PM	860	13.36	0.76	10.15	4.72
12:30 PM	876	13.35	0.78	10.41	4.75
12:45 PM	890	13.38	0.78	10.44	4.69
1:00 PM	880	13.39	0.79	10.58	4.81
1:15 PM	910	13.39	0.79	10.58	4.65
1:30 PM	930	13.4	0.79	10.59	4.55
1:45 PM	914	13.4	0.79	10.59	4.63
2:00 PM	870	13.41	0.81	10.86	4.99
2:15 PM	880	13.41	0.8	10.73	4.88
2:30 PM	850	13.42	0.79	10.6	4.99
2:45 PM	890	13.42	0.79	10.6	4.76
3:00 PM	860	13.45	0.75	10.09	4.69
3:15 PM	845	13.45	0.74	9.95	4.71
3:30 PM	790	13.48	0.75	10.11	5.12
3:45 PM	705	13.48	0.76	10.24	5.81
4:00 PM	710	13.51	0.76	10.27	5.78

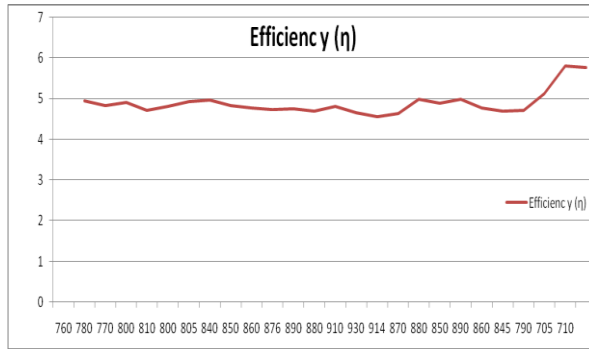

Figure 8: Efficiency V/s Solar Radiation Graph for static plate

Table III: Data Observation for Dual Axis Solar Tracking System on 25/10/2015

Time	Radiation (W/m <sup>2</sup> )	Current Supplied to Battery (I)	Power (W)	Efficiency (η)
10:00 AM	750	1.51	19.84	10.58
10:15 AM	770	1.52	19.99	10.38
10:30 AM	750	1.52	20.02	10.68
10:45 AM	780	1.52	20.02	10.27
11:00 AM	805	1.51	19.93	9.90
11:15 AM	809	1.51	19.93	9.86
11:30 AM	807	1.51	19.95	9.89
11:45 AM	810	1.51	19.95	9.85
12:00 PM	840	1.50	19.86	9.46
12:15 PM	850	1.50	19.88	9.35
12:30 PM	870	1.50	19.86	9.13
12:45 PM	880	1.49	19.73	8.97
1:00 PM	890	1.49	19.79	8.89
1:15 PM	905	1.48	19.65	8.69
1:30 PM	910	1.48	19.67	8.65
1:45 PM	904	1.48	19.67	8.70
2:00 PM	930	1.45	19.29	8.29
2:15 PM	870	1.45	19.29	8.87
2:30 PM	860	1.45	19.30	8.98
2:45 PM	850	1.45	19.30	9.08
3:00 PM	855	1.44	19.21	8.99
3:15 PM	830	1.44	19.21	9.26
3:30 PM	810	1.44	19.25	9.51
3:45 PM	760	1.43	19.12	10.06
4:00 PM	755	1.43	19.16	10.15

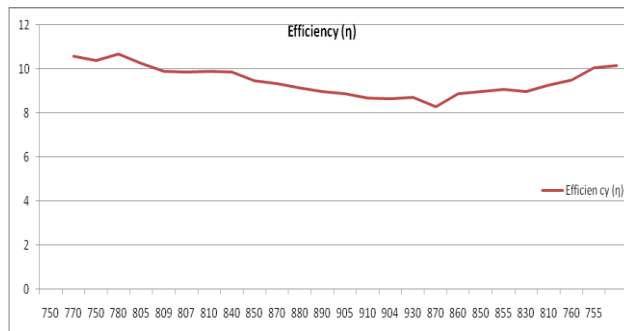

Figure 9: Efficiency V/s Solar Radiation Graph for Dual Axis solar System

Table IV: Data Observation for Static Solar System on 25/10/2015

Time	Radiation (W/m <sup>2</sup> )	Battery Voltage (V)	Battery Current (I)	Power (W)	Efficiency (η)
10:00 AM	750	13.14	0.76	9.99	5.33



10:15 AM	770	13.15	0.77	10.13	5.26
10:30 AM	750	13.17	0.77	10.14	5.41
10:45 AM	780	13.17	0.77	10.14	5.20
11:00 AM	805	13.20	0.76	10.03	4.98
11:15 AM	809	13.20	0.76	10.03	4.96
11:30 AM	807	13.21	0.76	10.04	4.98
11:45 AM	810	13.21	0.76	10.04	4.96
12:00 PM	840	13.24	0.75	9.93	4.73
12:15 PM	850	13.25	0.75	9.94	4.68
12:30 PM	870	13.24	0.75	9.93	4.57
12:45 PM	880	13.24	0.74	9.80	4.45
1:00 PM	890	13.28	0.74	9.83	4.42
1:15 PM	905	13.28	0.73	9.69	4.28
1:30 PM	910	13.29	0.73	9.70	4.26
1:45 PM	904	13.29	0.73	9.70	4.29
2:00 PM	930	13.30	0.7	9.31	4.00
2:15 PM	870	13.30	0.7	9.31	4.28
2:30 PM	860	13.31	0.7	9.32	4.33
2:45 PM	850	13.31	0.7	9.32	4.38
3:00 PM	855	13.34	0.69	9.20	4.31
3:15 PM	830	13.34	0.69	9.20	4.44
3:30 PM	810	13.37	0.69	9.23	4.56
3:45 PM	760	13.37	0.68	9.09	4.79
4:00 PM	755	13.40	0.68	9.11	4.83

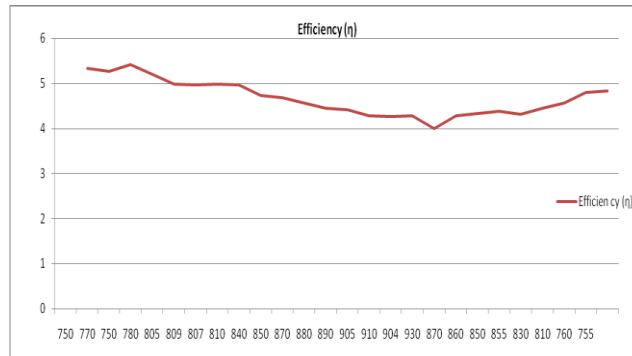

Figure 10: Efficiency V/s Solar Radiation Graph for static plate



Figure 10: Proposed Experimental Setup

## V. CONCLUSION

Reading was taken for both the system, for the static solar system and double-axis tracking system, and was compared from each other. The observation data was taken in Sept-Oct 2015. During these days the sky was clear on a maximum number of days. In this proposed system a systematic sampling, a packet is selected at a predefined fixed time (2 hours) count. In this study, fuzzy logic was used to implement the adaptive sampling. Fuzzy logic compares the intensity of 4 different Light Emitting Diode Voltage, which is developed due to sunlight. According to the voltage developed on LDRs, it gives its best orientation.

These readings were analyzed to determine whether the proposed system was successful or not. Analysis of reading taken during the experiment we have found that for every time dual-axis solar system, efficiency is always higher than the static solar system by amount approx. 5 %. In remote areas, such type of model can be used where the electricity is not available or for a home solar system. One more benefit of using the same system is that the cost of tariff is quite low as compared to the grid system.

## REFERENCES

- [1] G. Deb and A. B. Roy, "Use of the solar tracking system for extracting solar energy," *International Journal of Computer and Electrical Engineering*, vol. 4, no. 1, pp. 42–46, 2012.
- [2] T. Tudorache and L. Kreindler, "Design of a solar tracker system for PV power plants," *Acta Polytechnica Hungarica*, vol. 7, no. 1, pp. 23–39, 2010.
- [3] C.-L. Shen and C.-T. Tsai, "Double-linear approximation algorithm to achieve maximum-power-point tracking for photovoltaic arrays," *Energies*, vol. 5, no. 6, pp. 1982–1997, 2012.
- [4] K. Liu, "Dynamic characteristics and graphic monitoring design of photovoltaic energy conversion system," *WSEAS Transactions on Systems*, vol. 10, no. 8, pp. 239–248, 2011.
- [5] Jing Min Wang and chia Liang Lu, "Design and Implementation of Sun Tracker with a Dual Axis Single Motor for an optical sensor based photovoltaic system" *Sensors* 2013, pp 3157-3168, 6 March 2013.
- [6] Rashid Ahammed Firdaus, Mahir Ashif Mohmmmed, "Energy Efficient Hybrid Dual Axis Solar Tracking System" *Hindawi Publishing Corporation, Volume 2014, Article ID 629717* pages 12.
- [7] Abdallah, S.; Nijmeh, S. Two axes sun tracking system with PLC control. *Energy. Conv. Manag.* 2004, 45, 1931–1939.
- [8] Saravanan, C.; Panneerselvam, M.A.; Christopher, I.W. A novel low cost automatic solar tracking system. *Int. J. Comput. Appl.* 2011, 31, 62–67.
- [9] V S Siva Kumar and S Surya Narayana, "Automatic Dual Axis Sun Tracking System using LDR Sensor", *International Journal of Current Engineering and Technology*, E- ISSN2277 –4106, P-ISSN2347-5161, pp-3214-3217, Oct2014.
- [10] Binoy Seal, et al, "Comparision Between Different Solar Tracking System and Wireless Technology ", *International Journal of Advanced Research in Computer Science and Software Engineering*, ISSN: 2277 128X, Volume 4, Issue 4, pp. 487-490, April 2014.
- [11] Deepthi, et al, "Comparison of Efficiencies of Single-Axis Tracking System and Dual- Axis Tracking System with Fixed Mount", *International Journal of Engineering Science and Innovative Technology*, ISSN: 2319-5967, Volume 2, Issue 2, March 2013 pp. 425- 430.